

# DIMENSIONS OF SINGLE STAGE VERTICAL SPLITCASE PUMPS – SERIES HS

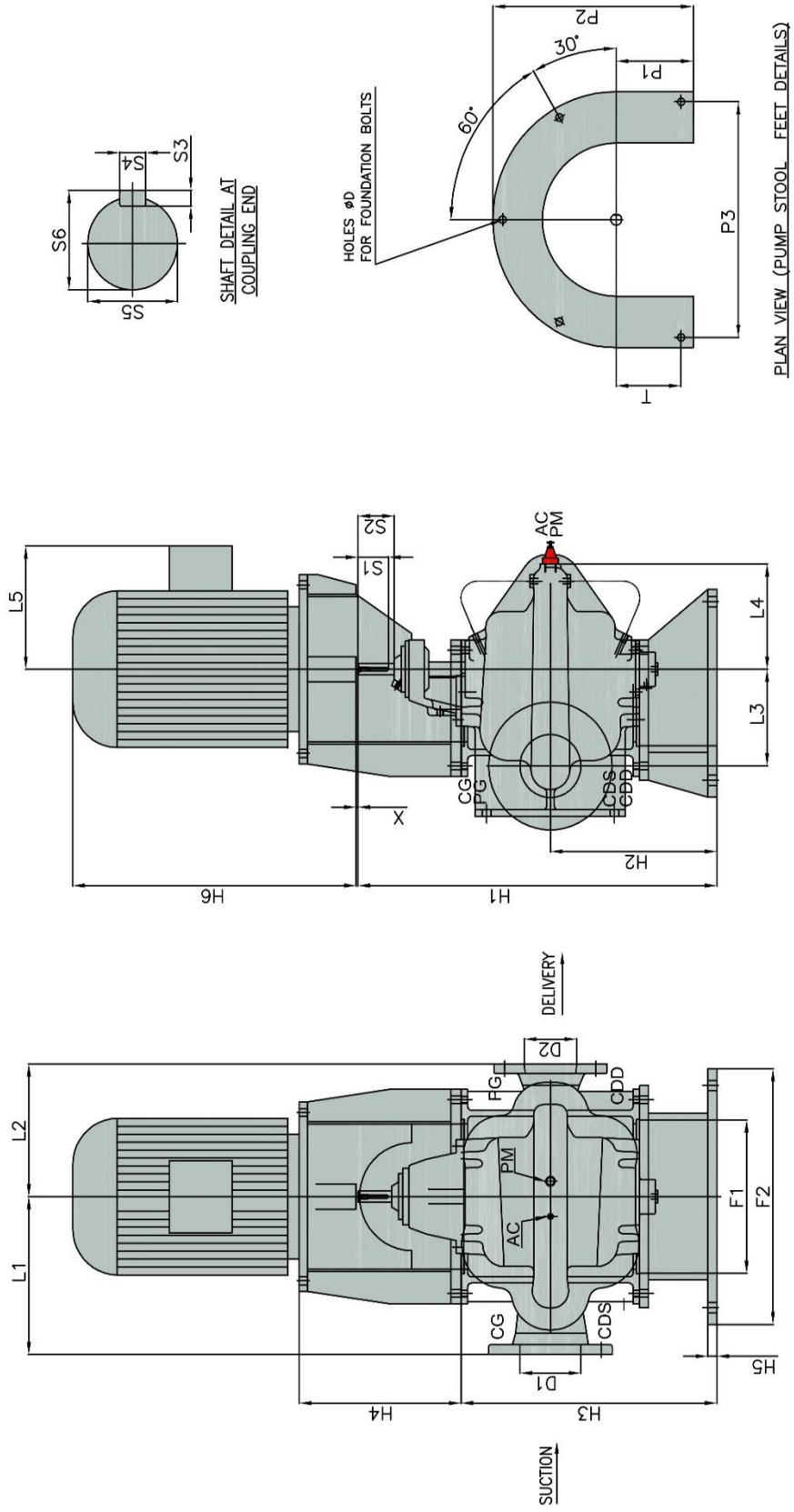

PLAN VIEW (PUMP STOOL FEET DETAILS)

SHAFT END DETAILS						
GROUP	S1	S2	S3	S4	S5	S6
1	70	82.5	7	8	27	30
2	80	89.5	8	12	38	42
3	85	100	9	14	50	53.5
4	100	125	12	20	69	74
5	125	155	14	22	76	82

ITEM	CONNECTION							
	DESCRIPTION	1	2	3	4	5	6	7
GD	GLAND DRAIN	1/2"	1/2"	3/4"	1"	1 1/2"	1"	1"
CG	COMP. GAUGE FOR SUCTION	3/8"	3/8"	3/8"	3/8"	3/8"	3/8"	3/8"
PG	PR. GAUGE FOR DELIVERY	3/8"	3/8"	3/8"	3/8"	3/8"	3/8"	3/8"
AC	AIR COCK	1/2"	3/4"	1"	1 1/2"	1"	1 1/4"	1 1/2"
PM	PRIMING	1/2"	3/4"	1"	1 1/2"	1"	1"	1"
CDS	CASING DRAIN (SUC. SIDE)	1/2"	3/4"	3/4"	1"	1"	1"	1"
CDD	CASING DRAIN (DEL. SIDE)	1/2"	3/4"	3/4"	1"	1"	1"	1"

SI No.	PUMP MODEL	MOTOR IN kW	FRAME SIZE	SIZE		SHAFT GROUP	OVER ALL DIMENSIONS											
				D1	D2		L1	L2	L3	L4	L5	H1	H2	H3	H4	H5	H6	x
1	V2HS13	7.5	132M	65	50	1	255	255	125	146	166	501	272	394	346	22	533	5
		9.3	160M								247				346	25	671	
		11.0	160M								247				346	25	671	
		15.0	160M								247				346	25	671	
2	V3HS13	37.0	225S	80	65	2	255	255	125	146	337	501	272	394	376	22	833	5
		45.0	225S								337				376	25	833	
		55.0	250M								362				376	25	910	
		75.0	280S								448				376	25	1040	
3	V4HS11	7.5	132M	125	100	1	270	220	195	215	166	891	410	630	346	25	587	5
		9.3	160M								247				346	25	671	
		11.0	160M								247				346	25	671	
		15.0	160M								247				346	25	671	
4	V4HS15	15.0	160M	125	100	1	370	300	230	260	247	891	410	630	346	25	671	5
		18.5	180M								266				346	25	706	
		22.0	180M								266				346	25	706	
		30.0	200M								284				346	25	731	
5	V4HS16	55.0	250M	125	100	1	385	315	245	275	362	781	340	560	376	25	910	5
		75.0	280S								448				376	25	1040	
		90.0	280S								448				376	25	1040	
		15.0	160M								247				346	25	671	
6	V5HS12	18.5	180M	150	125	1	330	265	210	245	266	891	410	630	346	25	706	5
		22.0	180M								266				346	25	706	
		15.0	160M								247				346	25	671	
		18.5	180M								266				346	25	706	
7	V5HS13	22.0	180M	150	125	1	350	286	213	240	266	891	410	630	346	25	706	5
		30.0	200M								284				346	25	731	
		15.0	160M								247				346	25	671	
		18.5	180M								266				346	25	706	
8	V5HS14	30.0	200M	150	125	1	375	315	230	250	266	781	340	560	346	25	706	5
		37.0	225S								337				376	25	833	
		45.0	225S								337				376	25	833	
		55.0	250M								362				376	25	910	
9	V5HS17	75.0	280S	150	125	2	420	305	270	300	448	971	340	560	376	25	1040	5
		37.0	225S								337				376	25	833	
		45.0	225S								337				376	25	833	
		55.0	250M								362				376	25	910	
10	V5HS19	75.0	280S	150	125	2	420	400	295	318	362	971	420	720	416	26	910	5
		90.0	280S								448				416	26	1040	
		110.0	315S								448				416	26	1040	
		55.0	250M								557				448	26	1199	

SI No.	PUMP MODEL	MOTOR IN kW	FRAME SIZE	BASE DIMENSIONS							SHAFT END						APPROX. WEIGHTS		
				F1	F2	P1	P2	P3	D	T	S1	S2	S3	S4	S5	S6	Bare Pump	Pump Stool	Motor Stool
1	V2HS13	7.5	132M	340	460	180	410	410	18	110	70	82.5	7	8	27	30.0	100	30	60
		9.3	160M																
		11.0	160M																
		15.0	160M																
2	V3HS13	37.0	225S	340	460	180	410	410	18	110	70	82.5	7	8	27	42.0	100	30	60
		45.0	225S																
		55.0	250M																
		75.0	280S																
3	V4HS11	7.5	132M	328	620	190	500	560	24	160	70	82.5	7	8	27	30.0	190	50	60
		9.3	160M																
		11.0	160M																
		15.0	160M																
4	V4HS15	15.0	160M	328	620	190	500	560	24	160	70	82.5	7	8	27	30.0	240	40	60
		18.5	180M																
		22.0	180M																
		30.0	200M																
5	V4HS16	55.0	250M	520	660	190	520	600	23	130	70	82.5	7	8	27	30.0	286	45	80
		75.0	280S																
		90.0	280S																
		15.0	160M																
6	V5HS12	18.5	180M	328	620	190	500	560	24	160	70	82.5	7	8	27	30.0	235	50	60
		22.0	180M																
		15.0	160M																
		18.5	180M																
7	V5HS13	22.0	180M	328	620	190	500	560	24	160	70	82.5	7	8	27	30.0	263	50	60
		30.0	200M																
		15.0	160M																
		18.5	180M																
8	V5HS14	30.0	200M	520	660	190	520	600	23	130	70	82.5	7	8	27	30.0	273	40	65
		37.0	225S																
		45.0	225S																
		55.0	250M																
9	V5HS17	75.0	280S	448	720	190	550	660	24	130	80	89.5	8	12	38	42.0	350	40	65
		37.0	225S																
		45.0	225S																
		55.0	250M																
10	V5HS19	75.0	280S	580	720	190	550	660	23	130	80	89.5	8	12	38	42.0	390	110	100
		90.0	280S																
		110.0	315S																
		55.0	250M																

SI No.	PUMP MODEL	MOTOR IN kW	FRAME SIZE	SIZE		SHAFT GROUP	OVER ALL DIMENSIONS											
				D1	D2		L1	L2	L3	L4	L5	H1	H2	H3	H4	H5	H6	x
11	V6HS12	18.5	180M	200	150	1	350	265	220	255	266	891	410	630	346	25	706	5
		22.0	180M								266				346		706	
		30.0	200M								284				346		731	
		37.0	225S								337				376		833	
12	V6HS14	30.0	200M	200	150	2	390	320	250	290	284	971	420	720	386	26	731	5
		37.0	225S								337				416		833	
		45.0	225S								337				416		833	
		55.0	250M								362				416		910	
		75.0	280S								448				416		1040	
		55.0	250M								362				416		910	
13	V6HS17	75.0	280S	200	150	2	410	360	270	315	448	971	420	720	416	26	1040	5
		90.0	280S								448				416		1040	
		90.0	280S								448				416		1040	
		90.0	280S								448				416		1040	
14	V6HS21	110.0	315S	200	150	3	440	430	320	355	557	1137	515	830	473	28	1040	5
		132.0	315S								557				503		1199	
		150.0	315M								557				503		1245	
		160.0	315M								557				503		1245	
		180.0	315M								557				503		1245	
		200.0	315M								557				503		1245	
		90.0	280S								448				473		1040	
		110.0	315S								557				503		1199	
15	V6HS23	132.0	315S	200	150	3	500	400	360	390	557	1137	515	830	473	28	1040	5
		150.0	315M								557				503		1245	
		160.0	315M								557				503		1245	
		180.0	315M								557				503		1245	
		90.0	280S								448				473		1040	
16	V8HS12	30.0	200M	200	200	2	400	320	250	290	284	971	420	720	386	26	731	5
		37.0	225S								337				416		833	
		45.0	225S								337				416		833	
		55.0	250M								362				416		910	
17	V8HS14	75.0	280S	250	200	2	440	350	285	330	448	971	420	720	416	26	1040	5
		90.0	280S								448				416		1040	
		110.0	315S								557				448		1199	
		45.0	225S								337				416		833	
		55.0	250M								362				416		910	
18	V8HS16	55.0	250M	200	200	2	420	350	270	330	362	971	420	720	416	26	1040	5
		75.0	280S								448				416		1040	
		90.0	280S								448				416		1040	
		110.0	315S								557				448		1199	
		75.0	280S								448				473		1040	
19	V8HS17	90.0	280S	200	200	3	450	400	300	345	448	1086	535	920	473	28	1040	5
		110.0	315S								448				473		1040	
		132.0	315S								557				503		1199	
		150.0	315M								557				503		1199	
		160.0	315M								557				503		1245	
		180.0	315M								557				503		1245	
		180.0	315M								557				503		1245	

SI No.	PUMP MODEL	MOTOR IN kW	FRAME SIZE	BASE DIMENSIONS							SHAFT END						APPROX. WEIGHTS		
				F1	F2	P1	P2	P3	D	T	S1	S2	S3	S4	S5	S6	Bare Pump	Pump Stool	Motor Stool
11	V6HS12	18.5	180M	328	620	190	500	560	24	160	70	82.5	7	8	27	30.0	345	50	60
		22.0	180M																
		30.0	200M																
		37.0	225S																
12	V6HS14	30.0	200M	580	720	190	550	660	23	130	80	83.5	8	12	38	42.0	415	110	100
		37.0	225S																
		45.0	225S																
		55.0	250M																
		75.0	280S																
		55.0	250M																
13	V6HS17	75.0	280S	580	720	190	550	660	23	130	80	83.5	8	12	38	42.0	450	110	100
		90.0	280S																
		90.0	280S																
		90.0	280S																
14	V6HS21	110.0	315S	594	860	300	730	780	24	260	85	100.0	9	14	50	53.5	600	119	145
		132.0	315S																
		150.0	315M																
		160.0	315M																
		180.0	315M																
		200.0	315M																
		90.0	280S																
15	V6HS23	110.0	315S	594	860	300	730	780	24	260	85	100.0	3	14	50	53.5	650	145	165
		132.0	315S																
		150.0	315M																
		160.0	315M																
		180.0	315M																
16	V8HS12	30.0	200M	580	720	190	550	660	23	130	80	83.5	8	12	38	42.0	370	110	100
		37.0	225S																
		45.0	225S																
		55.0	250M																
17	V8HS14	75.0	280S	580	720	190	550	660	23	130	80	83.5	8	12	38	42.0	520	110	100
		90.0	280S																
		110.0	315S																
		110.0	315S																
18	V8HS16	45.0	225S	580	720	190	550	660	23	130	80	83.5	8	12	38	42.0	475	110	100
		55.0	250M																
		75.0	280S																
		90.0	280S																
		110.0	315S																
19	V8HS17	75.0	280S	670	830	270	685	750	23	190	85	100.0	9	14	50	53.5	615	145	165
		90.0	280S																
		110.0	315S																
		132.0	315S																
		150.0	315M																
		160.0	315M																
		180.0	315M																

SI No.	PUMP MODEL	MOTOR IN kW	FRAME SIZE	SIZE		SHAFT GROUP	OVER ALL DIMENSIONS											
				D1	D2		L1	L2	L3	L4	L5	H1	H2	H3	H4	H5	H6	x
20	V8HS18TA	90.0	280S	250	200	3	450	365	295	340	448	1137	515	830	473	28	1040	5
		110.0	315S								503				1199			
		132.0	315S								503				1199			
		150.0	315M								503				1245			
		160.0	315M								503				1245			
		180.0	315M								503				1245			
		200.0	315M								503				1245			
21	V8HS18TB	90.0	280S	250	250	3	460	400	280	342	448	1137	515	830	473	28	1040	5
		110.0	315S								503				1199			
		132.0	315S								503				1199			
		150.0	315M								503				1245			
		160.0	315M								503				1245			
		180.0	315M								503				1245			
		200.0	315M								503				1245			
22	V8HS21	160.0	315M	200	200	3	500	400	360	385	557	1086	535	920	503	28	1245	5
		180.0	315M								503				1245			
		200.0	315M								503				1245			
		225.0	355S								533				1575			
		250.0	355S								533				1575			
23	V8HS21TA	160.0	315M	200	200	3	470	457	343	370	557	1086	535	920	503	28	1245	5
		180.0	315M								503				1245			
		200.0	315M								503				1245			
		225.0	355S								533				1575			
		250.0	355S								533				1575			
24	V8HS21TB	160.0	315M	200	200	3	470	457	343	370	557	1086	535	920	503	28	1245	5
		180.0	315M								503				1245			
		200.0	315M								503				1245			
		225.0	355S								533				1575			
		250.0	355S								533				1575			
25	V8HS22	150.0	315M	250	200	4	520	400	360	395	557	1232	540	880	548	32	1245	5
		160.0	315M								548				1245			
		180.0	315M								548				1245			
		200.0	315M								548				1245			
		225.0	355S								588				1575			
		250.0	355S								588				1575			
		315.0	355M								588				1650			
26	V8HS26	225.0	355S	250	200	4	580	480	430	450	610	1232	540	880	588	32	1575	5
		250.0	355S								610				1575			
		315.0	355M								610				1575			
27	V10HS13	75.0	280S	300	250	3	500	365	295	340	448	1136	535	920	473	28	1040	5
		90.0	280S								448				1040			
		110.0	315S								503				1199			
28	V10HS12	37.0	225S	250	250	2	475	380	275	323	337	971	420	720	416	26	833	5
		45.0	225S								337				833			
		55.0	250M								362				910			
		75.0	280S								448				1040			

SI No.	PUMP MODEL	MOTOR IN kW	FRAME SIZE	BASE DIMENSIONS							SHAFT END						APPROX. WEIGHTS		
				F1	F2	P1	P2	P3	D	T	S1	S2	S3	S4	S5	S6	Bare Pump	Pump Stool	Motor Stool
20	V8HS18TA	90.0	280S	594	860	300	730	780	24	260	85	100.0	9	14	50	53.5	605	145	165
		110.0	315S																
		132.0	315S																
		150.0	315M																
		160.0	315M																
		180.0	315M																
		200.0	315M																
21	V8HS18TB	90.0	280S	594	860	300	730	780	24	260	85	100.0	9	14	50	53.5	623	145	165
		110.0	315S																
		132.0	315S																
		150.0	315M																
		160.0	315M																
		180.0	315M																
		200.0	315M																
22	V8HS21	160.0	315M	670	830	270	685	750	23	190	85	100.0	9	14	50	53.5	615	145	165
		180.0	315M																
		200.0	315M																
		225.0	355S																
		250.0	355S																
23	V8HS21TA	160.0	315M	670	830	270	685	750	23	190	85	100.0	9	14	50	54.0	790	145	180
		180.0	315M																
		200.0	315M																
		225.0	355S																
		250.0	355S																
24	V8HS21TB	160.0	315M	670	830	270	685	750	23	190	85	100.0	9	14	50	54.0	715	145	180
		180.0	315M																
		200.0	315M																
		225.0	355S																
		250.0	355S																
25	V8HS22	150.0	315M	840	1000	-	1000	920	28	-	100	125.0	12	20	66	74.0	900	175	250
		160.0	315M																
		180.0	315M																
		200.0	315M																
		225.0	355S																
		250.0	355S																
		315.0	355M																
26	V8HS26	225.0	355S	840	1000	-	1000	920	28	-	100	125.0	12	20	66	74.0	1240	175	150
		250.0	355S																
		315.0	355M																
27	V10HS13	75.0	280S	670	830	270	685	750	23	190	85	100.0	9	14	50	54.0	575	145	150
		90.0	280S																
		110.0	315S																
28	V10HS12	37.0	225S	580	720	190	550	660	23	130	80	89.5	8	12	38	42.0	486	110	100
		45.0	225S																
		55.0	250M																
		75.0	280S																

SI No.	PUMP MODEL	MOTOR IN kW	FRAME SIZE	SIZE		SHAFT GROUP	OVER ALL DIMENSIONS										
				D1	D2		L1	L2	L3	L4	L5	H1	H2	H3	H4	H5	H6
29	V10HS15	132.0	315S	300	250	3	500	400	320	355	557	1086	465	780	503	28	1199
		150.0	315M								557				503		1245
		160.0	315M								557				503		1245
		180.0	315M								557				503		1245
		200.0	315M								557				503		1245
30	V10HS17	250.0	355S	300	250	3	500	400	335	375	610	1086	465	780	533	28	1575
		315.0	355M								610				533		1650
		150.0	315M								557				548		1245
31	V10HS22	160.0	315M	300	250	4	589	494	355	410	557	1480	589	1128	548	32	1245
		180.0	315M								557				548		1245
		200.0	315M								557				548		1245
		225.0	355S								557				548		1245
		250.0	355S								610				588		1575
		315.0	355M								610				588		1575
		150.0	315M								610				588		1650
32	V10HS22S	150.0	315M	300	250	4	589	494	355	410	557	1480	589	1128	548	32	1245
		160.0	315M								557				548		1245
		180.0	315M								557				548		1245
		200.0	315M								557				548		1245
		225.0	355S								610				588		1575
		250.0	355S								610				588		1575
		315.0	355M								610				588		1650
33	V10HS27	150.0	315M	305	254	5	640	560	407	476	557	1408	590	980	548	30	1245
		160.0	315M								557				548		1245
		180.0	315M								557				548		1245
		200.0	315M								557				548		1245
		225.0	355S								610				588		1575
		250.0	355S								610				588		1575
		315.0	355M								610				588		1650
34	V12HS13	90.0	280S	350	300	3	545	400	305	355	448	1272	635	995	460	25	1040
		110.0	315S								557				490		1199
		132.0	315S								557				490		1199
		150.0	315M								557				490		1245
		160.0	315M								557				490		1245
		180.0	315M								557				490		1245
		200.0	315M								557				490		1245
35	V12HS15	132.0	315S	350	300	3	550	365	335	375	557	1086	465	780	503	28	1199
		150.0	315M								557				503		1245
		160.0	315M								557				503		1245
		180.0	315M								557				503		1245
		200.0	315M								557				503		1245
		225.0	355S								610				533		1575
		315.0	355M								610				533		1650
36	V12HS16	132.0	315S	400	300	3	550	350	350	385	557	1184	520	890	490	28	1199
		150.0	315M								557				490		1245
		160.0	315M								557				490		1245
		180.0	315M								557				490		1245
		200.0	315M								557				490		1245
		225.0	355S								610				530		1575
		250.0	355S								610				530		1575

SI No.	PUMP MODEL	MOTOR IN kW	FRAME SIZE	BASE DIMENSIONS							SHAFT END						APPROX. WEIGHTS		
				F1	F2	P1	P2	P3	D	T	S1	S2	S3	S4	S5	S6	Bare Pump	Pump Stool	Motor Stool
29	V10HS15	132.0	315S	670	830	270	685	750	23	190	85	100.0	9	14	50	54.0	715	145	165
		150.0	315M																
		160.0	315M																
		180.0	315M																
		200.0	315M																
30	V10HS17	250.0	355S	670	830	270	685	750	23	190	85	100.0	9	14	50	53.5	890	145	170
		315.0	355M																
		150.0	315M																
31	V10HS22	150.0	315M	682	880	410	850	800	24	360	100	125.0	12	20	66	74.0	1000	175	250
		160.0	315M																
		180.0	315M																
		200.0	315M																
		225.0	355S																
		250.0	355S																
		315.0	355M																
32	V10HS22S	150.0	315M	682	880	410	850	800	24	360	100	125.0	12	20	66	74.0	1000	175	250
		160.0	315M																
		180.0	315M																
		200.0	315M																
		225.0	355S																
		250.0	355S																
		315.0	355M																
33	V10HS27	150.0	315M	734	1000	410	910	920	24	360	125	155.0	14	22	76	81.9	1500	178	260
		160.0	315M																
		180.0	315M																
		200.0	315M																
		225.0	355S																
		250.0	355S																
		315.0	355M																
34	V12HS13	90.0	280S	484	750	300	675	670	24	260	85	100.0	9	14	50	54.0	1043	145	87
		110.0	315S																
		132.0	315S																
		150.0	315M																
		160.0	315M																
		180.0	315M																
		200.0	315M																
35	V12HS15	132.0	315S	670	830	270	685	750	23	190	85	100.0	9	14	50	53.5	740	145	165
		150.0	315M																
		160.0	315M																
		180.0	315M																
		200.0	315M																
		225.0	355S																
		315.0	355M																
36	V12HS16	132.0	315S	670	830	270	685	750	23	190	85	100.0	9	14	50	53.5	655	145	160
		150.0	315M																
		160.0	315M																
		180.0	315M																
		200.0	315M																
		225.0	355S																
		250.0	355S																

Sl No.	PUMP	MOTOR	FRAME	SIZE		SHAFT	OVER ALL DIMENSIONS											x
				D1	D2		GROUP	L1	L2	L3	L4	L5	H1	H2	H3	H4	H5	
37	V12HS18	160.0	315M	400	300	4	575	475	345	378	557	1302	590	930	548	32	1245	5
		180.0	315M								557				548		1245	
		200.0	315M								557				548		1245	
		225.0	355S								610				588		1575	
		250.0	355S								610				588		1575	
		315.0	355M								610				588		1650	

Sl No.	PUMP	MOTOR	FRAME	BASE DIMENSIONS						SHAFT END						APPROX. WEIGHTS			
				F1	F2	P1	P2	P3	D	T	S1	S2	S3	S4	S5	S6	Bare Pump	Pump Stool	Motor Stool
37	V12HS18	160.0	315M	682	880	410	850	800	24	360	100	125.0	123	20	66	74.0	1095	175	250
		180.0	315M																
		200.0	315M																
		225.0	355S																
		250.0	355S																
		315.0	355M																