

**PUMP MODEL - 3HFT11**

**GENERAL ARRANGEMENT DRAWING FOR TWO STAGE AXIALLY SPLIT-CASE PUMP MODEL - 3HFT11**

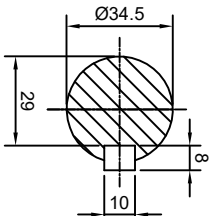
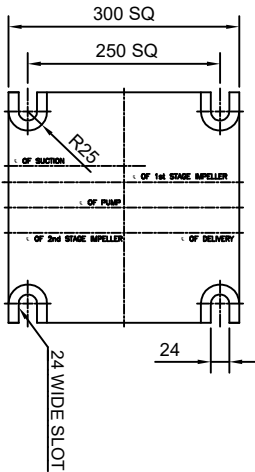
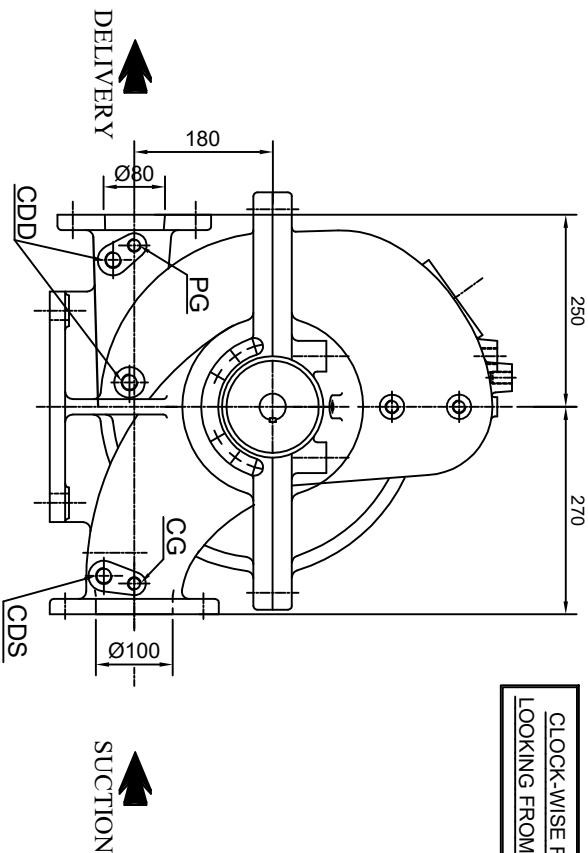
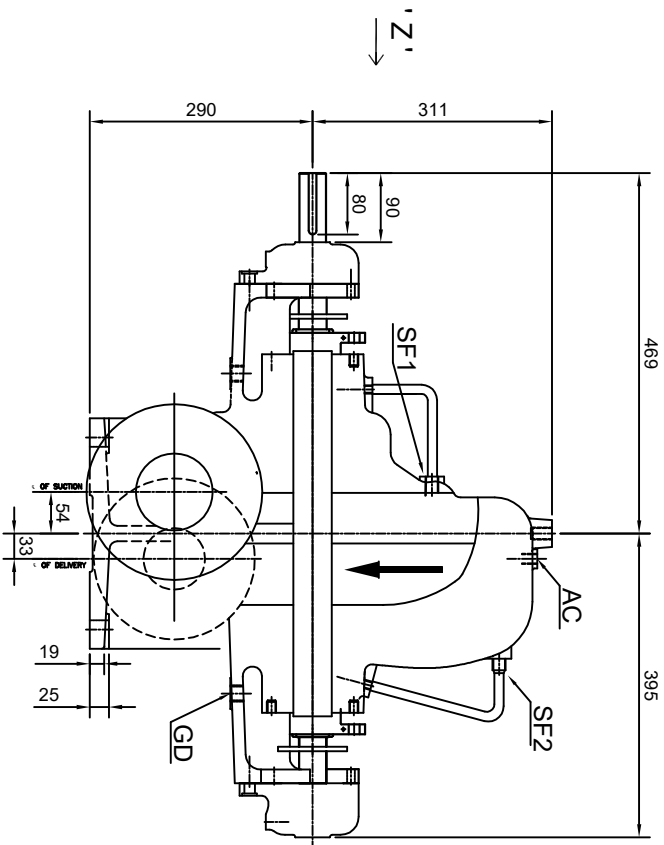

VIEW IN DIRECTION OF ' Z '

**DETAIL OF PUMP FEET**

**SCALE-4:1  
SHAFT DETAILS  
AT COUPLING END**

**APPROX. NETT WEIGHT - 312kg.  
ALL DIMENSIONS ARE IN MM.**

ITEM	CONNECTION	DESCRIPTION	SIZE(NPT)
GD		GLAND DRAIN	1/2"
CG		COMPOUND GAUGE FOR SUCTION	3/8"
PG		PRESSURE GAUGE FOR DELIVERY	3/8"
AC		AIR COCK (SUITS FOR AARV)	1/2"
PMI		PRIMING	3/8"
CDS		CASING DRAIN(SUCTION SIDE)	1/2"
CDD		CASING DRAIN(DELIVERY SIDE)	1/2"



**Underwriters  
Laboratories**

**PUMPSENSE**



S	ANSI#125	9"	7-1/2"	15/16"	8, 3/4"	--	8-1/4"	6-5/8"	1-1/8"	8, 7/8"
REF. NO.	TYPE OF FLANGE.	O.D.	P.C.D.	THK MIN	NO SIZE OF HOLE	O.D.	P.C.D.	THK MIN	NO SIZE OF HOLE	
		SUCTION 100Ø				DELIVERY 80Ø				

REV	DESCRIPTION	DRN	CHKD	APPD

TITLE				SCALE	
GA DRAWING FOR 3HFT11				1:1	
DRN	AD	DATE	DRW. NO.	DEPARTMENT NO.	REV
CHKD	ST	13.02.15	3HFT11/GA-01/0	9023550	0
	HS	13.02.15			