

PUMP MODEL - 6HFTD12L

GENERAL ARRANGEMENT DRAWING FOR TWO STAGE AXIALLY SPLIT-CASE PUMP MODEL - 6HFTD12L

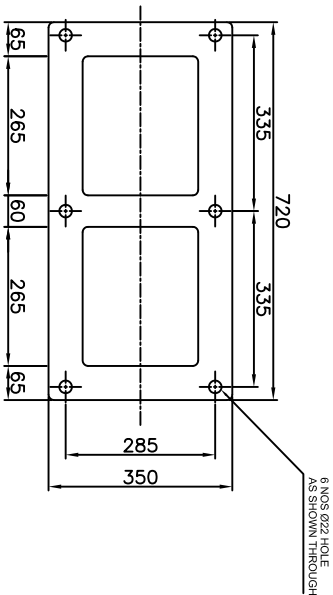

PLAN OF PUMP FEET

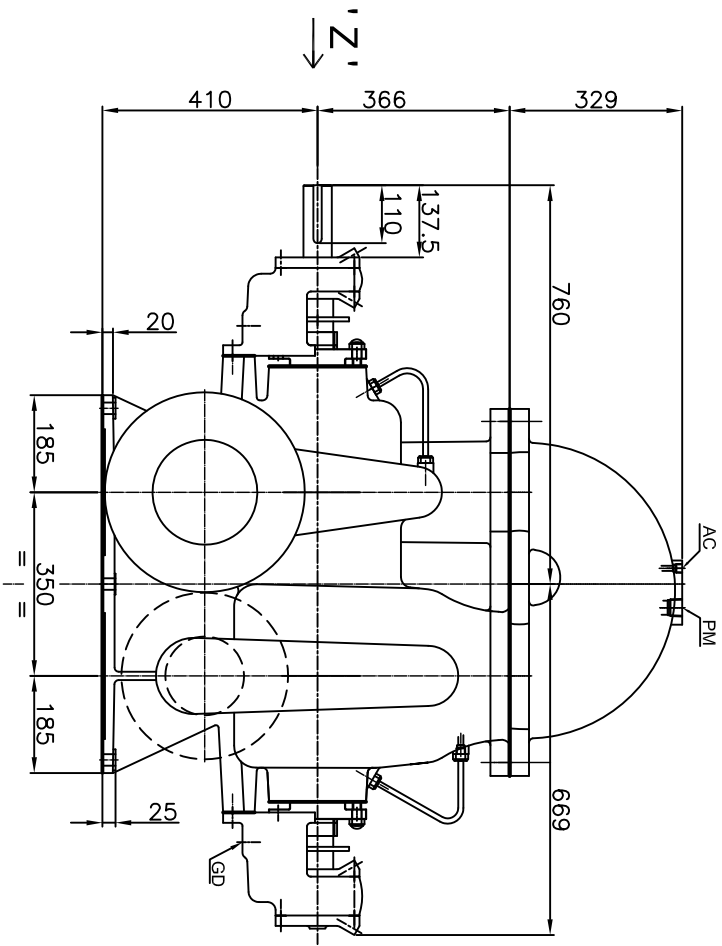
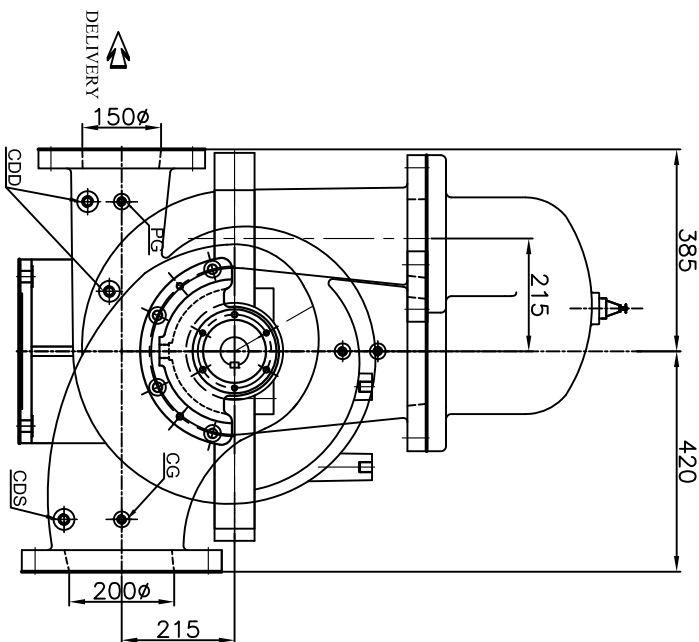

VIEW IN DIRECTION OF 'Z'

CLOCK WISE ROTATION
LOOKING FROM DRIVE END

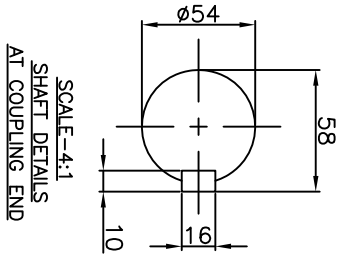

SCALE-4:1
SHAFT DETAILS
AT COUPLING END

APPROX. NETT WEIGHT - 970kg.
ALL DIMENSIONS ARE IN MM.



Underwriters
Laboratories

CONNECTIONS		SIZE(NPT)
ITEM	DESCRIPTION	
GD	GLAND DRAIN	3/4"
CG	COMPOUND GAUGE FOR SUCTION	3/8"
PG	PRESSURE GAUGE FOR DELIVERY	3/8"
AC	AIR COCK	3/8"
PM	PRIMING	1"
CDS	CASING DRAIN(SUCTION SIDE)	1/2"
CDD	CASING DRAIN(DELIVERY SIDE)	1/2"

DEL	ANSI 250#FF	12-1/2"	10-5/8"	1-7/16"	12.Ø7/8"	---	---	---
SUC 200Ø	ANSI 250#FF	15"	13"	1-5/8"	12.Ø1"	---	---	---
TYPE OF FLANGE		O.D.	P.C.D.	THK	NO & HOLE Ø	RFØ	RF THK	RF FLANGE

REV	DESCRIPTION	DRN	CHKD	DATE	APPD	SCALE
						1:1
						0

TITLE -
PUMPSENSE
GA DRG. FOR 6HFTD12L



DRN	AD	17.08.18	DRG. NO.
CHKD	SR	17.08.18	PSF/6HFTD12L/GA-01
APPD	HS	17.08.18	